

**DO NOT OPEN THIS TEST BOOKLET UNTIL YOU ARE ASKED TO DO SO**

T. B. C. : PGT – 2/20

Test Booklet Series

**A**

**TEST BOOKLET**

**PART – B  
(PHYSICS)**

Sl. No. **20201**

Time Allowed : 2 Hours

Maximum Marks : 100

**: INSTRUCTIONS TO CANDIDATES :**

1. IMMEDIATELY AFTER THE COMMENCEMENT OF THE EXAMINATION, YOU SHOULD CHECK THAT THIS TEST BOOKLET **DOES NOT** HAVE ANY UNPRINTED OR TORN OR MISSING PAGES OR ITEMS ETC. IF SO, GET IT REPLACED BY A COMPLETE TEST BOOKLET OF THE SAME SERIES ISSUED TO YOU.
2. ENCODE CLEARLY THE TEST BOOKLET SERIES **A, B, C OR D**, AS THE CASE MAY BE, IN THE APPROPRIATE PLACE IN THE ANSWER SHEET USING BALL POINT PEN (BLUE OR BLACK).
3. You have to enter your **Roll No.** on the Test Booklet in the Box provided alongside. **DO NOT** write *anything else* on the Test Booklet.
4. **YOU ARE REQUIRED TO FILL UP & DARKEN ROLL NO., TEST BOOKLET / QUESTION BOOKLET SERIES IN THE ANSWER SHEET AS WELL AS FILL UP TEST BOOKLET / QUESTION BOOKLET SERIES AND SERIAL NO. AND ANSWER SHEET SERIAL NO. IN THE ATTENDANCE SHEET CAREFULLY. WRONGLY FILLED UP ANSWER SHEETS ARE LIABLE FOR REJECTION AT THE RISK OF THE CANDIDATE.**
5. This Test Booklet contains **100** items (questions). Each item (question) comprises four responses (answers). You have to select the correct response (answer) which you want to mark (darken) on the Answer Sheet. In case, you feel that there is more than one correct response (answer), you should mark (darken) the response (answer) which you consider the best. In any case, choose **ONLY ONE** response (answer) for each item (question).
6. You have to mark (darken) all your responses (answers) **ONLY** on the **separate Answer Sheet** provided, by using **BALL POINT PEN (BLUE OR BLACK)**. See instructions in the Answer Sheet.
7. All items (questions) carry equal marks. All items (questions) are compulsory. Your total marks will depend only on the number of correct responses (answers) marked by you in the Answer Sheet. There will be no negative marking for wrong answer.
8. Before you proceed to mark (darken) in the Answer Sheet the responses (answers) to various items (questions) in the Test Booklet, you have to fill in some particulars in the Answer Sheet as per the instructions sent to you with your **Admission Certificate**.
9. After you have completed filling in all your responses (answers) on the Answer Sheet and after conclusion of the examination, you should hand over to the Invigilator the *Answer Sheet* issued to you. You are allowed to take with you the candidate's copy / second page of the Answer Sheet along with the **Test Booklet**, after completion of the examination, for your reference.
10. Sheets for rough work are appended in the Test Booklet at the end.

**DO NOT OPEN THIS TEST BOOKLET UNTIL YOU ARE ASKED TO DO SO**

1. The value of integral around the unit circle in complex plane is :

- (A)  $1 + i$
- (B)  $i$
- (C)  $-i$
- (D)  $1 - i$

polynomials  $P_n(x)$  is  $F(x, t) = (1 - 2xt + t^2)^{-1/2}$ . The value of  $P_3(-1)$

is :

- (A)  $-1/2$
- (B)  $1/2$
- (C)  $+1$
- (D)  $-1$

2. The standard Legendre differential equation is :

- (A)  $(1-x^2) \frac{d^2y}{dx^2} - 2x \frac{dy}{dx} + l(l+1)y = 0$
- (B)  $(1-x^2) \frac{d^2y}{dx^2} - 2x \frac{dy}{dx} + (x^2 - n^2)y = 0$
- (C)  $(1-x^2) \frac{d^2y}{dx^2} - \frac{dy}{dx} + l(l+1)y = 0$
- (D)  $(1-x^2) \frac{d^2y}{dx^2} - 2x \frac{dy}{dx} = 0$

4. The generating function of Bessel function is :

- (A)  $(1-x^2) \frac{d^2y}{dx^2} - 2x \frac{dy}{dx} + l(l+1)y = 0$
- (B)  $(1-x^2) \frac{d^2y}{dx^2} - 2x \frac{dy}{dx} + (x^2 - n^2)y = 0$
- (C)  $(1-x^2) \frac{d^2y}{dx^2} - \frac{dy}{dx} + l(l+1)y = 0$
- (D)  $(1-x^2) \frac{d^2y}{dx^2} - 2x \frac{dy}{dx} = 0$

3. The generating function  $F(x, t) =$

$\sum_{n=0}^{\infty} P_n(x)t^n$  for the Legendre

(D)  $(1-x^2) \frac{d^2y}{dx^2} - 2x \frac{dy}{dx} = 0$

5. The Green's function  $G(x, x')$ , for the equation  $\frac{d^2y(x)}{dx^2} = f(x)$ , with the boundary values  $y(0) = 0$  and  $y(1) = 0$ , is :

(A)  $G(x, x') =$

$$\begin{cases} \frac{1}{2}x(1-x'), & 0 < x < x' < 1 \\ \frac{1}{2}x'(1-x), & 0 < x' < x < 1 \end{cases}$$

(B)  $G(x, x') =$

$$\begin{cases} x(x'-1), & 0 < x < x' < 1 \\ x'(1-x), & 0 < x' < x < 1 \end{cases}$$

(C)  $G(x, x') =$

$$\begin{cases} -\frac{1}{2}x(1-x'), & 0 < x < x' < 1 \\ \frac{1}{2}x'(1-x), & 0 < x' < x < 1 \end{cases}$$

(D)  $G(x, x') =$

$$\begin{cases} x(x'-1), & 0 < x < x' < 1 \\ x'(x-1), & 0 < x' < x < 1 \end{cases}$$

6. The number of independent parameters of the group  $O(3)$  and  $SU(2)$  are :

(A) 3, 3

(B) 3, 2

(C) 2, 2

(D) 2, 3

7. Which of the following is not an  $SU(2)$  matrix ?

(A)  $\begin{pmatrix} e^{i\theta} & 0 \\ 0 & e^{-i\theta} \end{pmatrix}$

(B)  $\begin{pmatrix} 0 & e^{i\theta} \\ -e^{i\theta} & 0 \end{pmatrix}$

(C)  $\begin{pmatrix} 1 & 1 \\ 1 & 1 \end{pmatrix}$

(D)  $\begin{pmatrix} 0 & i \\ i & 0 \end{pmatrix}$

8. The number of independent components of a real antisymmetric tensor of rank two in 4 dimensions is :

(A) 4

(B) 6

(C) 8

(D) 10

9. Two tensors are called conjugate tensors if they are :

(A) Symmetric and reciprocal

(B) Symmetric but not reciprocal

(C) Reciprocal but not symmetric

(D) Neither symmetric nor reciprocal

10. A one to one mapping of a finite group onto itself is :

- (A) Isomorphism
- (B) Homomorphism
- (C) Automorphism
- (D) Monomorphism

11. Lienard – Wiechert potentials are the :

- (A) Vector potentials due to a moving point charge
- (B) Scalar potentials due to a moving point charge
- (C) Vector and scalar potentials due to a static point charge
- (D) Vector and scalar potentials due to a moving point charge

12. The Poisson's equation for the electrostatic potential  $\phi$  is :

- (A)  $\nabla^2\phi = \frac{\rho}{\epsilon_0}$
- (B)  $\nabla^2\phi = \int_v \frac{\rho}{\epsilon_0} dv$
- (C)  $\nabla \times \phi = \frac{\rho}{\epsilon_0}$
- (D)  $\nabla^2\phi = -\frac{\rho}{\epsilon_0}$

13. The electrostatic field at a distance  $r$  from the center of a uniformly charged

sphere of radius  $R$  varies as (for  $r \leq R$ ) is proportional to :

- (A)  $\frac{1}{r^2}$
- (B)  $\frac{1}{r}$
- (C)  $r$
- (D)  $r^2$

14. The electric field of an electromagnetic wave is given by  $\vec{E} = E_0 \cos [\pi(0.3x + 0.4y - 1000t)] \hat{k}$ . The associated magnetic field  $\vec{B}$  is :

- (A)  $10^{-3} E_0 \cos [\pi(0.3x + 0.4y - 1000t)] \hat{k}$
- (B)  $10^{-4} E_0 \cos [\pi(0.3x + 0.4y - 1000t)] (4\hat{i} - 3\hat{j})$
- (C)  $E_0 \cos [\pi(0.3x + 0.4y - 1000t)] (0.3\hat{i} + 0.4\hat{j})$
- (D)  $10^2 E_0 \cos [\pi(0.3x + 0.4y - 1000t)] (3\hat{i} + 4\hat{j})$

15. The electric flux through any closed surface is a measure of :

- (A) The total charge inside the surface
- (B) The total charge outside the surface
- (C) The total charge at the surface
- (D) The total charge, both, inside and outside the surface

16. Two large metal sheets having surface charge density  $+\sigma$  and  $-\sigma$  are kept parallel to each other as a small separation distance  $d$ . The electric field at any point in the region between the plates is :

(A)  $\frac{\sigma}{2\epsilon_0}$

(B)  $\frac{2\sigma}{\epsilon_0}$

(C)  $\frac{\sigma}{\epsilon_0}$

(D)  $\frac{\sigma}{4\epsilon_0}$

17. An electrostatic field is said to be conservative, when :

(A) Divergence of the electric field is zero

(B) Curl of the electric field is zero

(C) Curl of the electric field is equal

to  $-\frac{\partial B}{\partial t}$

(D) The Laplacian of the electric field is zero

18. A point charge  $q$  is at a distance  $d$  from a conducting plane, the energy required to move the charge to infinitely away from the plane is :

(A)  $-\frac{q^2}{4d}$

(B)  $-\frac{q^2}{4d^2}$

(C)  $-\frac{q}{d}$

(D)  $-qd$

19. The Poynting theorem is a law of conservation of :

(A) Energy

(B) Momentum

(C) Orbital angular momentum

(D) Spin angular momentum

20. According to Rayleigh scattering, the intensity of scattered light is proportional to :

(A)  $\lambda^4$

(B)  $\frac{1}{\lambda}$

(C)  $\frac{1}{\lambda^4}$

(D)  $\lambda$

21. The selection rule for Raman spectrum is :

(A)  $\Delta J = 0$

(B)  $\Delta J = \pm 1$

(C)  $\Delta J = \pm 3$

(D)  $\Delta J = \pm 2$

22. Consider a particle of mass  $m$  in the potential  $V(x) = a|x|$ ,  $a > 0$ . The energy eigenvalues  $E_n$  ( $n = 0, 1, 2, \dots$ ) in the WKB approximation, are :

(A)  $\left[ \frac{3a\pi\hbar}{4\sqrt{2m}} \left( n + \frac{1}{2} \right) \right]$

(B)  $\left[ \frac{3a\pi\hbar}{4\sqrt{2m}} \left( n + \frac{1}{2} \right) \right]^{\frac{2}{3}}$

(C)  $\left[ \frac{3a\pi\hbar}{4\sqrt{2m}} \left( n + \frac{1}{2} \right) \right]^{\frac{4}{3}}$

(D)  $\left[ \frac{3a\pi\hbar}{4\sqrt{2m}} \left( n + \frac{1}{2} \right) \right]^{\frac{1}{3}}$

23. During relativistic motion :

(A)  $\vec{L}$  is constant of motion

(B)  $\vec{S}$  is constant of motion

(C) There is no constant of motion

(D)  $\vec{J} = \vec{L} + \vec{S}$  is constant of motion

24. Scattering of a free particle in a central potential is :

(A) Not accompanied by phase shift

(B) Accompanied by particle production

(C) Always accompanied by phase shift

(D) Accompanied by absorption

25. In scattering experiments, the differential cross-section for spherically symmetric potential  $V(r)$  using Born approximation is :

(A)  $\frac{d\sigma(\theta)}{d\Omega} = \left( \frac{2\mu}{\hbar^2} \right)^2 \left| \int_0^\infty V(r) \right.$

$\left. \left[ \frac{\sin qr}{qr} \right] r^2 dr \right|^2$

(B)  $\frac{d\sigma(\theta)}{d\Omega} = \left| \int_0^\infty V(r) \right.$

$\left. \left[ \frac{\sin qr}{qr} \right] r^2 dr \right|^2$

(C)  $\frac{d\sigma(\theta)}{d\Omega} = \left( \frac{2\mu}{\hbar^2} \right)^2 \left| \int_0^\infty V(r) \right.$

$\left. \left[ \frac{\cos qr}{qr} \right] r^2 dr \right|^2$

(D)  $\frac{d\sigma(\theta)}{d\Omega} = \left( \frac{2\mu}{\hbar^2} \right)^2 \left| \int_0^\infty V(r) \right.$

$\left. \left[ \frac{1}{qr} \right] r^2 dr \right|^2$

26. The Born-Oppenheimer approximation is related to :

- (A) The nuclei also move in relation to the more fast moving electrons
- (B) The nuclei move with the same velocity as the fast-moving electrons
- (C) The nuclei remain stationary in relation to the fast-moving electrons
- (D) The nuclei move faster than the fast moving electrons

27. A particle in 1D moves under the influence of a potential  $V(x) = ax^6$ , where  $a$  is a real constant for large  $n$ , the quantized energy level  $E_n$  depends on 'n' as :

- (A)  $E_n \approx n^3$
- (B)  $E_n \approx n^4$
- (C)  $E_n \approx n^5$
- (D)  $E_n \approx n^2$

28. The Klein-Gordon equation for a free particle of rest mass 'm' is :

$$(A) \quad -\hbar^2 \frac{\partial^2 \psi}{\partial t^2} = -\hbar^2 c^2 \nabla^2 \psi + m^2 c^4 \psi$$

$$(B) \quad \hbar^2 \frac{\partial^2 \psi}{\partial t^2} = -\hbar^2 c^2 \nabla^2 \psi + m^2 c^4 \psi$$

$$(C) \quad -\hbar^2 \frac{\partial^2 \psi}{\partial t^2} = -\hbar^2 c^2 \nabla^2 \psi - m^2 c^4 \psi$$

$$(D) \quad \hbar^2 \frac{\partial^2 \psi}{\partial t^2} = \hbar^2 c^2 \nabla^2 \psi + m^2 c^4 \psi$$

29. The Klein-Gordon equation is used to describe a particle with spin :

- (A)  $\hbar$
- (B)  $2\hbar$
- (C) zero
- (D)  $\frac{\hbar}{2}$

30. The transition rate between two quantum states  $|m\rangle$  and  $|n\rangle$  due to spontaneous emission is proportional to \_\_\_\_\_, where  $W_{mn} =$

$$\frac{(E_m - E_n)}{\hbar}$$

$$(A) \quad W_{mn}^3 \left| \langle m | \vec{r} | n \rangle \right|^2$$

$$(B) \quad W_{mn} \left| \langle m | \vec{r} | n \rangle \right|^2$$

$$(C) \quad W_{mn}^2 \left| \langle m | \vec{r} | n \rangle \right|^2$$

$$(D) \quad W_{mn} \left| \langle m | \vec{r} | n \rangle \right|^2$$

31. The relation between group velocity ( $V_g$ ) and phase velocity ( $V_p$ ) for non-dispersive medium :

(A)  $V_g \neq V_p$

(B)  $V_g = V_p$

(C)  $V_g > V_p$

(D)  $V_g < V_p$

32. The uncertainty for the Gaussian wave packet is :

(A)  $\Delta \hat{x} \Delta \hat{P}_x = 0$

(B)  $\Delta \hat{x} \Delta \hat{P}_x = \hbar$

(C)  $\Delta \hat{x} \Delta \hat{P}_x = \hbar/2$

(D)  $\Delta \hat{x} \Delta \hat{P}_x \geq \hbar/2$

33. The uncertainty relation between two operators  $\hat{A}$  and  $\hat{B}$  is :

(A)  $\Delta A \Delta B \geq \langle [\hat{A}, \hat{B}] \rangle$

(B)  $\Delta A \Delta B \geq \frac{1}{2} |\langle [\hat{A}, \hat{B}] \rangle|$

(C)  $\Delta A \Delta B \leq \frac{1}{2} |\langle [\hat{A}, \hat{B}] \rangle|$

(D)  $\Delta A \Delta B \leq \langle [\hat{A}, \hat{B}] \rangle$

34. The commutation relation for angular momentum L is :

(A)  $[L^2, L_x] = 0$

(B)  $[L^2, L_x] = 1$

(C)  $[L^2, L_x] = L_x$

(D)  $[L^2, L_x] = L^2$

35. Consider a matrix  $A =$

$$\begin{pmatrix} 5 & 3+2i & 3i \\ -i & 3i & 8 \\ 1-i & 1 & 4 \end{pmatrix}, |\psi\rangle = \begin{pmatrix} -1+i \\ 3 \\ 2+3i \end{pmatrix}$$

$\langle \phi | = (6 -i 5)$ . Calculate the quantity

$\langle \phi | A | \psi \rangle$ :

(A)  $70 - 155i$

(B)  $70 + 155i$

(C)  $40 + 60i$

(D)  $59 + 155i$

36. The Pauli spin matrix for  $S = \frac{1}{2}$ :

(A)  $S_x = \frac{\hbar}{2} \begin{pmatrix} 0 & -1 \\ 1 & 0 \end{pmatrix}, S_y =$

$$\frac{\hbar}{2} \begin{pmatrix} 0 & i \\ i & 0 \end{pmatrix}, S_z = \frac{\hbar}{2} \begin{pmatrix} 1 & 0 \\ 0 & -1 \end{pmatrix}$$

(B)  $S_x = \frac{\hbar}{2} \begin{pmatrix} 0 & -i \\ i & 0 \end{pmatrix}, S_y =$

$$\frac{\hbar}{2} \begin{pmatrix} 0 & 1 \\ 1 & 0 \end{pmatrix}, S_z = \frac{\hbar}{2} \begin{pmatrix} 1 & 0 \\ 0 & -1 \end{pmatrix}$$

(C)  $S_x = \frac{\hbar}{2} \begin{pmatrix} 0 & 1 \\ 1 & 0 \end{pmatrix}, S_y =$

$$\frac{\hbar}{2} \begin{pmatrix} 0 & -i \\ i & 0 \end{pmatrix}, S_z = \frac{\hbar}{2} \begin{pmatrix} 1 & 0 \\ 0 & -i \end{pmatrix}$$

(D)  $S_x = \frac{\hbar}{2} \begin{pmatrix} 0 & 1 \\ 1 & 0 \end{pmatrix}, S_y =$

$$\frac{\hbar}{2} \begin{pmatrix} 0 & -i \\ i & 0 \end{pmatrix}, S_z = \frac{\hbar}{2} \begin{pmatrix} 1 & 0 \\ 0 & -1 \end{pmatrix}$$



37. The momentum operator  $\hat{p}$  is represented by :

(A)  $\hat{p} = \hbar \vec{\nabla}$

(B)  $\hat{p} = -\hbar \vec{\nabla}$

(C)  $\hat{p} = -i \hbar \vec{\nabla}$

(D)  $\hat{p} = i \hbar \vec{\nabla}$

38. The generalized energy term for the particle constrained in a 3-D box is :

(A)  $E_{n_x n_y n_z}(x, y, z) = \frac{\hbar^2 \pi^2}{2m} \left( \frac{n_x^2}{L_x^2} + \frac{n_y^2}{L_y^2} + \frac{n_z^2}{L_z^2} \right)$

(B)  $E_{n_x n_y n_z}(x, y, z) = \frac{\hbar^2 \pi^2}{6m} \left( \frac{n_x^2}{L_x^2} + \frac{n_y^2}{L_y^2} + \frac{n_z^2}{L_z^2} \right)$

(C)  $E_{n_x n_y n_z}(x, y, z) = \frac{1}{2m} \left( \frac{n_x^2}{L_x^2} + \frac{n_y^2}{L_y^2} + \frac{n_z^2}{L_z^2} \right)$

(D)  $E_{n_x n_y n_z}(x, y, z) = \frac{1}{4m} \left( \frac{n_x^2}{L_x^2} + \frac{n_y^2}{L_y^2} + \frac{n_z^2}{L_z^2} \right)$

39. The radial wave function  $R_{10}$  for the Hydrogen atom is :

(A)  $2a^{3/2} \exp(-r/a)$

(B)  $2a^{3/2} \exp(r/a)$

(C)  $a^{3/2} \exp(-r/a)$

(D)  $a^{3/2} \exp(r/a)$

40. In the normal Zeeman effect, the central spectral line is :

(A) Circularly polarized

(B) Elliptically polarized

(C) Not polarized

(D) Plane polarized

41. Which one of the property is not true for Dirac matrices ( $\alpha$  and  $\beta$ ) ?

(A) Trace of  $\alpha$  and  $\beta$  is zero

(B) Square of  $\alpha$  and  $\beta$  is identity

(C) Eigenvalues of  $\alpha$  and  $\beta$  are  $\pm 1$

(D) Trace of  $\alpha$  and  $\beta$  is one

42. In Dirac theory, the magnetic moment of Dirac particle is obtained in the :

(A) Relativistic limit

(B) Non-relativistic limit

(C) Saturation limit

(D) Non-central approximation

43. WKB approximation often referred as :

- (A) Semi classical approximation
- (B) Classical approximation
- (C) Quantum approximation
- (D) Weak approximation

44. According to Noether's theorem, which statement is correct ?

- (A) Linear and angular momentum is not conserved for the system when Lagrangian is independent of the origin and angle of measurement respectively.
- (B) Linear and angular momentum is conserved for the system when Lagrangian is independent of the origin and angle of measurement, respectively.
- (C) The energy of the system is not conserved for the system when Lagrangian is independent of base time.
- (D) None of these

45. The Dirac Hamiltonian is represented as :

- (A)  $H = \frac{\hbar c}{i} \left[ \alpha_1 \frac{\partial}{\partial x} - \alpha_2 \frac{\partial}{\partial y} - \alpha_3 \frac{\partial}{\partial z} \right] + \beta m_0 c^2$
- (B)  $H = \frac{-\hbar c}{i} \left[ \alpha_1 \frac{\partial}{\partial x} + \alpha_2 \frac{\partial}{\partial y} + \alpha_3 \frac{\partial}{\partial z} \right] + \beta m_0 c^2$
- (C)  $H = \frac{\hbar c}{i} \left[ \alpha_1 \frac{\partial}{\partial x} + \alpha_2 \frac{\partial}{\partial y} + \alpha_3 \frac{\partial}{\partial z} \right] + \beta m_0 c^2$
- (D)  $H = \frac{\hbar c}{i} \left[ \alpha_1 \frac{\partial}{\partial x} + \alpha_2 \frac{\partial}{\partial y} + \alpha_3 \frac{\partial}{\partial z} \right] - \beta m_0 c^2$

46. The four independent solution for Dirac wave functions for the free particle at rest is :

(A)  $\begin{pmatrix} 1 \\ 0 \\ 0 \\ 0 \end{pmatrix} e^{-\frac{imc^2t}{\hbar}}, \begin{pmatrix} 0 \\ 1 \\ 0 \\ 0 \end{pmatrix} e^{-\frac{imc^2t}{\hbar}},$

$\begin{pmatrix} 0 \\ 0 \\ 1 \\ 0 \end{pmatrix} e^{\frac{imc^2t}{\hbar}}, \begin{pmatrix} 0 \\ 0 \\ 0 \\ 1 \end{pmatrix} e^{\frac{imc^2t}{\hbar}}$

(B)  $\begin{pmatrix} 1 \\ 0 \\ 0 \\ i \end{pmatrix} e^{-\frac{imc^2t}{\hbar}}, \begin{pmatrix} 0 \\ i \\ 0 \\ 0 \end{pmatrix} e^{-\frac{imc^2t}{\hbar}},$

$\begin{pmatrix} 1 \\ 0 \\ i \\ 0 \end{pmatrix} e^{\frac{imc^2t}{\hbar}}, \begin{pmatrix} 0 \\ 0 \\ 0 \\ i \end{pmatrix} e^{\frac{imc^2t}{\hbar}}$

(C)  $\begin{pmatrix} 1 \\ 0 \\ 0 \\ 0 \end{pmatrix} e^{\frac{imc^2t}{\hbar}}, \begin{pmatrix} 0 \\ 1 \\ 0 \\ 0 \end{pmatrix} e^{\frac{imc^2t}{\hbar}},$

$\begin{pmatrix} 0 \\ 0 \\ 1 \\ 0 \end{pmatrix} e^{\frac{imc^2t}{\hbar}}, \begin{pmatrix} 0 \\ 0 \\ 0 \\ 1 \end{pmatrix} e^{\frac{imc^2t}{\hbar}}$

(D)  $\begin{pmatrix} -1 \\ 0 \\ 0 \\ 0 \end{pmatrix} e^{-\frac{imc^2t}{\hbar}}, \begin{pmatrix} 0 \\ -1 \\ 0 \\ 0 \end{pmatrix} e^{-\frac{imc^2t}{\hbar}},$

$\begin{pmatrix} 0 \\ 0 \\ 1 \\ 0 \end{pmatrix} e^{-\frac{imc^2t}{\hbar}}, \begin{pmatrix} 0 \\ 0 \\ 0 \\ 1 \end{pmatrix} e^{-\frac{imc^2t}{\hbar}}$

47. The extremely fast oscillating of Dirac electron is called :

- (A) Bremsstrahlung
- (B) Zitterbewegung
- (C) Helicity
- (D) None of these

48. The notion of particles and anti-particles is based on the solutions of :

- (A) Klein-Gordon equation
- (B) Dirac equation
- (C) Boltzmann equation
- (D) Schrodinger equation

49. In a b. c. c. lattice with lattice constant 'a', the body centered position from the origin is at a distance of :

- (A)  $\sqrt{2} a$
- (B)  $\frac{\sqrt{3}a}{2}$
- (C)  $\frac{\sqrt{3}}{2} a$
- (D)  $\frac{\sqrt{3}}{4} a$

50. If the X-ray wavelength  $\lambda = a$ , is reflected from the (111) plane of a simple cubic lattice with the lattice constant a, the corresponding Bragg's angle (in radian) is :

- (A)  $\frac{\pi}{6}$

(B)  $\frac{\pi}{4}$

(C)  $\frac{\pi}{3}$

(D)  $\frac{\pi}{8}$

51. A substance  $A_x B_y$  crystallizes in fcc lattice form in which A atoms occupy each corner of the cube and B atoms occupy the center of each face of the cube. Identify the correct composition of the substance  $A_x B_y$  :

- (A)  $A_4 B_3$
- (B)  $A_3 B$
- (C)  $AB_3$
- (D)  $A_2 B_2$

52. The maximum packing efficiency is observed in :

- (A) BCC
- (B) FCC
- (C) SCC
- (D) BCT

53. Calculate the hall voltage when the electric field is 5 V/m and height of the semiconductor is 2 cm ?

- (A) 0.1 V
- (B) 1 V
- (C) 0.01 V
- (D) 10 V

54. For a close packed BCC structure of hard spheres, the lattice constant 'a' is related to the sphere of radius R as :

(A)  $a = \frac{4R}{\sqrt{3}}$

(B)  $a = \frac{2R}{\sqrt{3}}$

(C)  $a = 4\sqrt{2} R$

(D)  $a = 2\sqrt{2} R$

55. The superconducting transition temperature of mercury (Hg) is :

(A) 2.4 K

(B) 6.4 K

(C) 4.2 K

(D) 1.6 K

56. The binding energy of a cooper pair is :

(A)  $10^{-2}$  eV

(B)  $10^{-3}$  eV

(C)  $10^{-4}$  eV

(D)  $10^{-6}$  eV

57. The ideal super conductors exhibit :

(A) Meissner effect

(B) Mesmeric effect

(C) Mesomeric effect

(D) Monomeric effect

58. According to Curie-Weiss law, the magnetic susceptibility of a material varies as :

(A)  $\frac{1}{T^2}$

(B)  $T^2$

(C)  $\frac{1}{T}$

(D)  $\frac{1}{T^3}$

59. The magnetic susceptibility of a diamagnetic and paramagnetic substance are :

(A) Negative and positive

(B) Negative and negative

(C) Positive and negative

(D) Positive and positive

60. The Bohr magneton ( $\mu_B$ ) is given by :

(A)  $\frac{eh}{2\pi m_e}$

(B)  $\frac{e\hbar}{4\pi m_e}$

(C)  $\frac{e\hbar}{2m_e}$

(D)  $\frac{eh}{2m_e}$

61. I-V characteristics of a tunnel diode is given by :

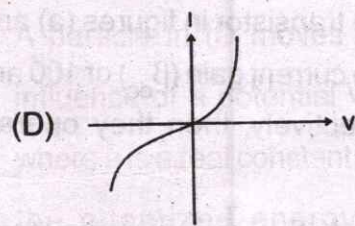
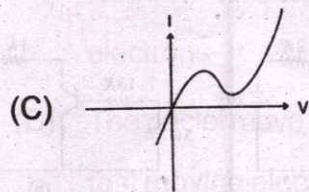
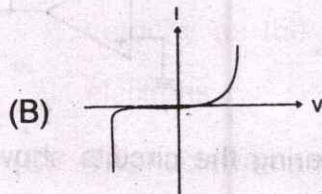
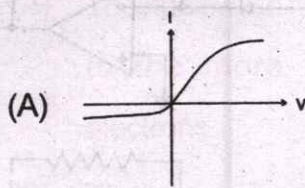

62. A certain op-amp has an open loop gain of 200000 and its common mode gain is 2. Then the Common Mode Rejection Ratio (CMRR) of the op-amp is :

- (A) 20 dB
- (B) 40 dB
- (C) 60 dB
- (D) 100 dB

63. An op-amp has a gain bandwidth product of 1.5 MHz. If the closed loop gain is 10, then the operating bandwidth would be :

- (A) 1.5 MHz
- (B) 150 kHz
- (C) 15 MHz
- (D) 15 kHz

64. An analog transducer has range of 0-10 V. How many bits of A/D converter is required to get the resolution of 5 mV ?

- (A) 10
- (B) 9
- (C) 11
- (D) 8

65. To get an output of 1 from the circuit given below, ABC should be :

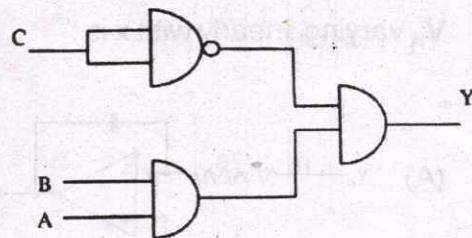

- (A) 000
- (B) 110
- (C) 010
- (D) 001

66. Which of the following is not a transducer ?

- (A) Strain gauge
- (B) Microphone
- (C) Thermo couple
- (D) Potentiometer

67. The minimum number of NOR gates required to implement a AND function is :

- (A) 5
- (B) 4
- (C) 3
- (D) 2

68. If the parameters  $y$  and  $x$  are related by  $y = \log x$ , then the circuit that can be used to produce an output voltage  $V_o$  varying linearly with  $x$  is :

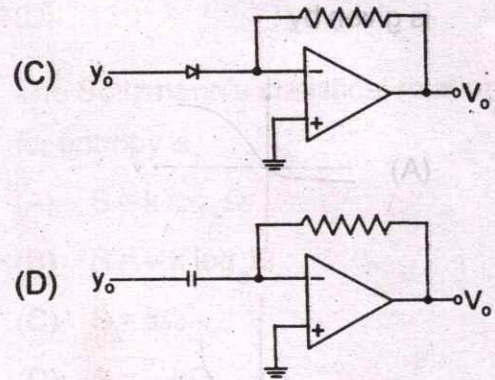
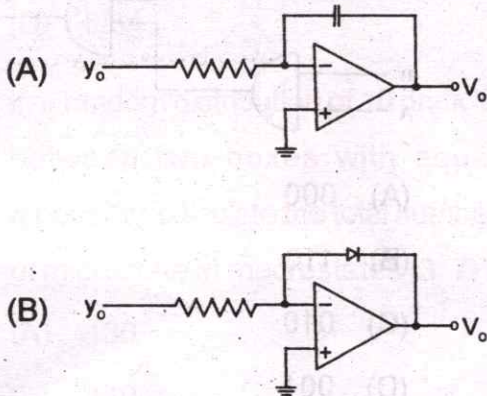

69. Considering the circuits shown in figure (a) and (b) :

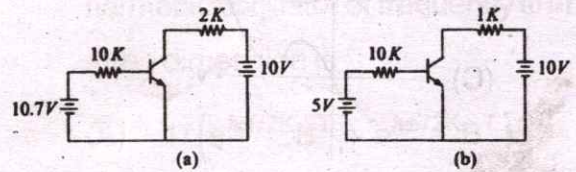

If the transistor in figures (a) and (b) have current gain ( $\beta_{dc}$ ) of 100 and 10 respectively, then they operate in the :

- (A) Active region and saturation region respectively
- (B) Saturation region and active region respectively
- (C) Saturation region in both cases
- (D) Active region in both cases

70. The Hamilton's canonical equations of motion are :

- (A)  $\dot{q}_k = \partial H / \partial p_k, \dot{p}_k = -\partial H / \partial q_k$
- (B)  $\dot{q}_k = -\partial H / \partial p_k, \dot{p}_k = -\partial H / \partial q_k$
- (C)  $\dot{q}_k = -\partial H / \partial q_k, \dot{p}_k = -\partial H / \partial p_k$
- (D)  $\dot{q}_k = \partial H / \partial q_k, \dot{p}_k = -\partial H / \partial p_k$

71. The Hamilton's equation of harmonic oscillator with kinetic energy  $\frac{1}{2}m\dot{x}^2$  and potential energy  $=\frac{1}{2}kx^2$  is :

- (A)  $\dot{x} = -p_x/m, \dot{p}_x = -kx$   
 (B)  $\dot{x} = p_x/m, \dot{p}_x = -kx$   
 (C)  $\dot{x} = p_x/m, \dot{p}_x = kx$   
 (D)  $\dot{x} = -p_x/m, \dot{p}_x = -kx$

72. Hamilton canonical equation of motion for conservative system are :

- (A)  $\partial q_i/\partial t = \partial H/\partial p_i, -\partial p_i/\partial t = \partial H/\partial q_i$   
 (B)  $\partial p_i/\partial t = \partial H/\partial p_i, -\partial q_i/\partial t = \partial H/\partial q_i$   
 (C)  $\partial q_i/\partial t = -\partial H/\partial p_i, \partial p_i/\partial t = \partial H/\partial q_i$   
 (D)  $\partial p_i/\partial t = -\partial H/\partial p_i, \partial q_i/\partial t = \partial H/\partial q_i$

73. If the Hamiltonian for system in two dimensional is  $H = \frac{p_x^2 + p_y^2}{2m} - \frac{K}{r}$ .

The Poisson bracket  $\{p_x, H\}$  is :

- (A) Zero  
 (B)  $P_x/m$   
 (C)  $-k/r^3$   
 (D)  $-k/r^2$

74. Identify the Jacobi's identify :

- (A)  $[F, [G, K]] + [G, [K, F]] + [K, [F, G]] = 0$

(B)  $[F, [G, K]] - [G, [K, F]] + [K, [F, G]] = 0$

(C)  $[F, [G, K]] + [G, [K, F]] + [K, [F, G]] = 1$

(D)  $[F, [G, K]] - [G, [K, F]] + [K, [F, G]] = 1$

75. The Poisson bracket for the component  $\{x, p_x\}$  is :

- (A) 1  
 (B) 0  
 (C)  $i\hbar$   
 (D)  $\hbar$

76. The number of degrees of freedom for rigid body which can move freely in space :

- (A) 9  
 (B) 6  
 (C) 3  
 (D) 1

77. Moment of inertia of thin rod about the mid-point of the rod perpendicular to length is :

- (A)  $I = MI^2/3$   
 (B)  $I = MI^2/4$   
 (C)  $I = MI^2/6$   
 (D)  $I = MI^2/12$

78. Hamilton's principal section  $S$  and Hamilton's characteristic function  $W$  for conservative systems are related as :
- (A)  $S = W$   
 (B)  $S = W - Et$   
 (C)  $S = W + Et$   
 (D)  $S = W + Et^2$
79. A boiled egg will spin faster than raw egg because of :
- (A) High moment of inertia  
 (B) Low moment of inertia  
 (C) High angular velocity  
 (D) Zero moment of inertia
80. Eight similar coins are tossed for a large number of times. Calculate the probability of getting the head of 5 coins :
- (A)  $7/32$   
 (B)  $8/32$   
 (C)  $7/64$   
 (D)  $8/64$
81. In a random distribution of 10 particle between two boxes with equal probability, calculate the total number of microstate in macrostates (3, 7) :
- (A) 130  
 (B) 140  
 (C) 139  
 (D) 120
82. The Boltzmann's statistical relation for entropy is :
- (A)  $S = k \log_e \Omega$   
 (B)  $S = -k \log_e \Omega$   
 (C)  $S = k\Omega$   
 (D)  $S = -k\Omega$
83. The canonical partition function of  $N$  non-interacting quantum mechanical harmonic oscillator of frequency  $\omega$  in three dimension is :
- (A)  $1/(e^{\hbar\omega/2K_B T} + e^{\hbar\omega/2K_B T})$   
 (B)  $1/(e^{\hbar\omega/2K_B T} + e^{\hbar\omega/2K_B T})^{3N}$   
 (C)  $1/(e^{\hbar\omega/2K_B T} - e^{\hbar\omega/2K_B T})^{3N}$   
 (D)  $1/(e^{\hbar\omega/K_B T} - e^{\hbar\omega/2K_B T})$
84. The grand-canonical ensemble is the collection of large systems having the same :
- (A) Energy( $E$ ), volume( $V$ ), number of particle ( $N$ )  
 (B) Temperature( $T$ ), volume( $V$ ), number of identical particle ( $N$ )  
 (C) Temperature( $T$ ), volume( $V$ ), chemical potential ( $\mu$ )  
 (D) Energy( $E$ ), volume( $V$ ), pressure( $P$ )



85. Most probable distribution of the particle among various energy levels for a system obeying Fermi-Dirac statistics :

(A)  $n_i = \frac{g_i}{e^{\alpha + \beta e_i} + 1}$

(B)  $n_i = \frac{1}{e^{\alpha + \beta e_i} - 1}$

(C)  $n_i = \frac{1}{e^{\alpha + \beta e_i} + 1}$

(D)  $n_i = \frac{g_i}{e^{\alpha + \beta e_i} - 1}$

86. The Planck's radiation law is :

(A)  $\frac{8\pi hc}{\lambda^5} 1/(e^{ch/\lambda KT} - 1) d\lambda$

(B)  $\frac{4\pi hc}{\lambda^5} 1/(e^{ch/\lambda KT} - 1) d\lambda$

(C)  $\frac{12\pi hc}{\lambda^5} 1/(e^{ch/\lambda KT} - 1) d\lambda$

(D)  $\frac{8\pi hc}{\lambda^5} 1/(e^{ch/\lambda KT} + 1) d\lambda$

87. With reference to the thermal behaviour of any material, the "Triple point" is :

(A) The temperature at which the material exists in all the three phases, i.e. vapour, liquid and solid, at the same time

(B) The pressure at which the material exists in all the three phases, i.e. vapour, liquid and

solid at the same time

(C) The temperature at which the material exists in only liquid and solid phase simultaneously

(D) The material exists in the solid phase only

88. The surface temperature of the Sun of solar radiation  $\lambda_m = 4753 \text{ \AA}$  and Wien's constant is  $2.898 \times 10^{-3}$  metre-kelvin is :

(A) 5097K

(B) 6097K

(C) 8000K

(D) 800K

89. The binding energy of deuteron is (mass of proton = 1.00727 u, the mass of neutron = 1.008665 u) :

(A) 2.23 MeV

(B) 4.23 MeV

(C) 40.23 MeV

(D) 20.30 MeV

90. The intrinsic quadrupole moment of the nucleus is :

(A)  $Q_0 = \frac{1}{e} \int (3z - r^2) \rho(r) dr$

(B)  $Q_0 = \frac{1}{e} \int (3z^2 - r^2) \rho(r) dr$

(C)  $Q_0 = \frac{1}{e} \int (3z^2 + r^2) \rho(r) dr$

(D) None of these

91. The electron capture is represented by:

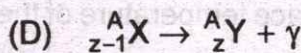
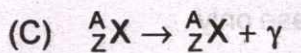
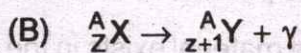
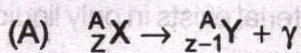

92. The parity of the deuteron ground state is:

(A) Odd

(B) Even

(C) Zero

(D) Complex

93. The expression for total scattering cross-section is:

(A)  $\sigma_{\text{tot}} = \frac{6\pi \sin^2 \delta_0}{k^2}$

(B)  $\sigma_{\text{tot}} = \frac{8\pi \sin^2 \delta_0}{k^2}$

(C)  $\sigma_{\text{tot}} = \frac{2\pi \sin^2 \delta_0}{k^2}$

(D)  $\sigma_{\text{tot}} = \frac{4\pi \sin^2 \delta_0}{k^2}$

94. The conserved property of the reaction  $p \rightarrow \pi^0 + e^+$ :

(A) Only Lepton number is conserved

(B) Only Baryon number is conserved

(C) Charge is conserved

(D) Both Lepton and Baryon number is conserved

95. Expression for the magnetic moment of the deuteron is:

(A)  $\mu_d = (\mu_n + \mu_p)S + \frac{1}{2}L$

(B)  $\mu_d = (\mu_n - \mu_p)S + \frac{1}{2}L$

(C)  $\mu_d = (\mu_n + \mu_p)S - \frac{1}{2}L$

(D)  $\mu_d = (\mu_n + \mu_p) + \frac{1}{2}L$

96. The Bethe-Weizker formula for binding energy is:

(A)  $E_B(A, Z) = a_1 A + a_2 A^{\frac{2}{3}} - a_3 \frac{Z^2}{A^{\frac{1}{3}}} - a_4 \frac{(A - 2Z)^2}{A} + \delta$

(B)  $E_B(A, Z) = a_1 A - a_2 A^{\frac{2}{3}} - a_3 \frac{Z^2}{A^{\frac{1}{3}}} - a_4 \frac{(A - 2Z)^2}{A} + \delta$

(C)  $E_B(A, Z) = a_1 A + a_2 A^{\frac{2}{3}} + a_3 \frac{Z^2}{A^{\frac{1}{3}}} - a_4 \frac{(A - 2Z)^2}{A} + \delta$

(D)  $E_B(A, Z) = -a_1 A + a_2 A^{\frac{2}{3}} - a_3 \frac{Z^2}{A^{\frac{1}{3}}} + a_4 \frac{(A - 2Z)^2}{A} + \delta$

97. Using shell model, predict the characteristics of the ground state of  $^{13}\text{C}$ :

(A)  $\frac{3^-}{2}$

(B)  $\frac{1^-}{2}$

(C)  $\frac{3^+}{2}$

(D)  $\frac{1^+}{2}$

98. Which of the following statement is not valid for the given reaction

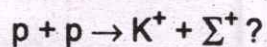

(A) Charge is conserved

(B) Strangeness is conserved

(C) Isotopic spin  $i_3$  is not conserved

(D) Strangeness is not conserved

99. The ground state spin and parity of

$^{13}\text{Al}^{27}$  is:

(A)  $\frac{3^+}{2}$

(B)  $\frac{5^+}{2}$

(C)  $\frac{1^+}{2}$

(D)  $\frac{3^-}{2}$

100. Write the Quark content for p, n and

$\Delta^+$ :

(A) uud, udd, uud

(B) uud, udd, uus

(C) uud, udd, uss

(D) uud, udd, udd

.....

**SPACE FOR ROUGH WORK**

state spin and parity of

Using shell model

97

characteristics of the ground state of

$^{13}\text{C}$

(A)  $\frac{3}{2}^+$

(B)  $\frac{1}{2}^+$

(C)  $\frac{3}{2}^-$

(D)  $\frac{1}{2}^-$

98 Which of the following statement is

not valid for the given reaction



(A) Charge is conserved

(B) Strangeness is conserved

(C) Isotopic spin is not conserved

(D) Strangeness is not conserved

100 Write the Quark content for p, n and

(A) uud, udd, uud

(B) uud, udd, uus

(C) uud, udd, uds

(D) uud, udd, udb

\*\*\*\*\*